

Assembly Instructions

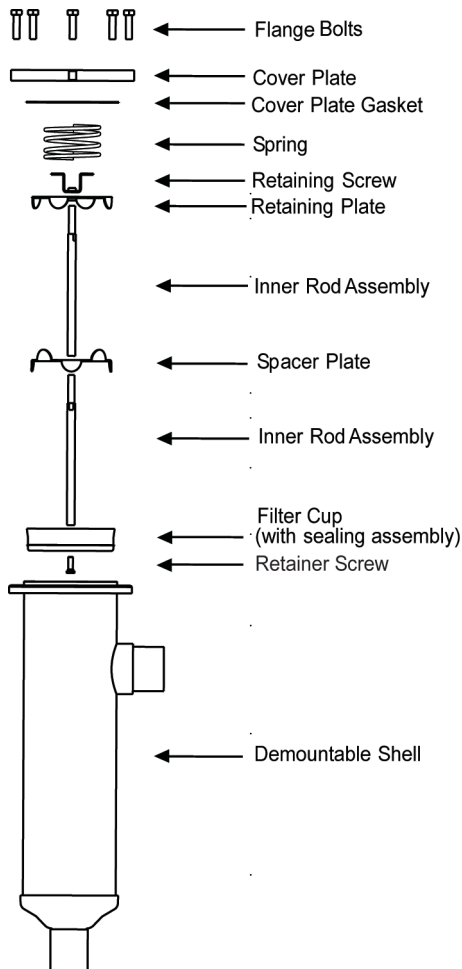

1. Pump the system down completely.
2. Ensure drier is isolated.
CAUTION: Failure to do so could result in serious injury.
3. Remove bolts, cover plate and drier internals, place in a container.
4. Clean all parts thoroughly
5. Break seal and open can for new drier block (or felt filter) and reassemble drier as shown.
CAUTION: Don't break seal until drier is ready to be installed, then install drier as quickly as possible.
6. Slip new block (or felt filter) onto inner rod assembly. For multiple core units place gasket and spacer plate between blocks (or filters).
7. Screw retaining screw firmly into inner rod assembly and insert assembled unit into shell after ensuring that neoprene gauze sealing gasket is located correctly.
8. Install new flange gasket into groove of cover plate.
9. Place small amount of thread lubricant on all bolts.
10. Tighten all cover plate bolts in a star like pattern - Tighten to 34 Nm (25 lbf Ft).
11. Leak test installation
CAUTION: Failure to do so could result in lost refrigerant.
12. Write refrigerant and oil type on side of vessel.

Attention:

The gasket supplied and fitted to the shell is for manufacturer leak testing purposes. Upon initial installation or core change, ensure existing gasket is replaced, by gasket supplied with demountable shell or supplied with the replacement core.



Do not use felt filter on the liquid line